

These instructions cover the assembly of the Radish, in addition to what's in the Longtail Kit instructions and the standard Xtracycle manual. Please refer to the Xtracycle manual for information regarding warranty, accessories, and ways to have fun with your new bike!

These instructions assume that you have some familiarity with working on bikes, and can judge the reliability of what you've put together. If not, take the kit to your local bike shop. This instruction sheet should provide them with all of the extra information needed to put your Radish together.

You will need the following tools to assemble the Radish: A bike stand, a 3, 4, and 5mm allen wrench, a Phillips screwdriver, a crescent wrench, a pedal wrench, a bike pump, and an attitude.

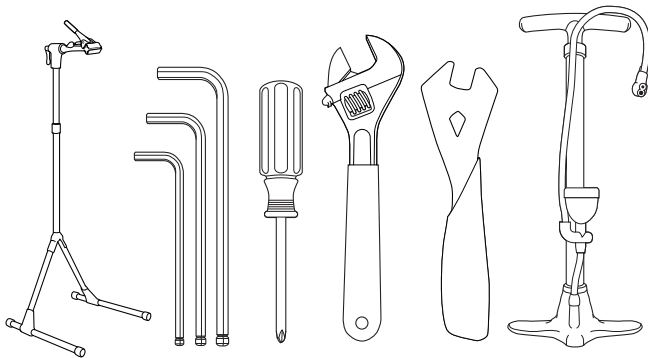

# IMPORTANT!

Before you start, know that there is a right and a very, very wrong way to install a Quick Release attachment. Doing this wrong may result in severe injury, property damage, mockery from your peers, or death. Seriously.

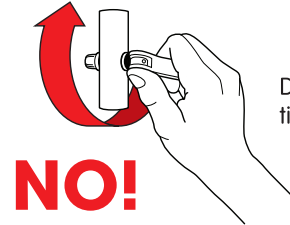

**NO!**

Do not rotate or twist the lever to tighten the bolt!

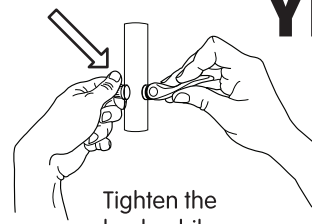

Tighten the knob while lever is open...

**YES!**

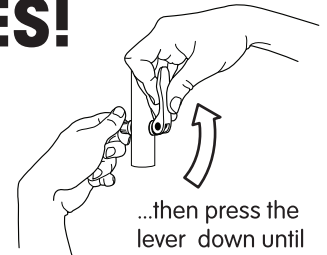

...then press the lever down until it's very tight.

**STEP 1**

## Let's begin!

The Radish kit consists of two major parts: the Radish Frame and the Free Radical attachment. Start by placing the bike frame in a stand.

Free Radical

Radish Frame

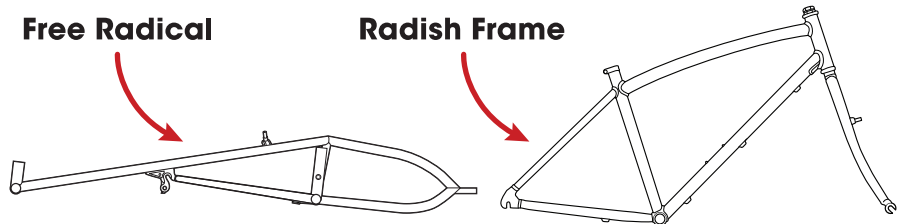

**STEP 2**

Insert the matching quick release bolts into the uprights as shown. Each quick release gets a washer on the outside and a French Nut (a T-shaped nut) on the end.

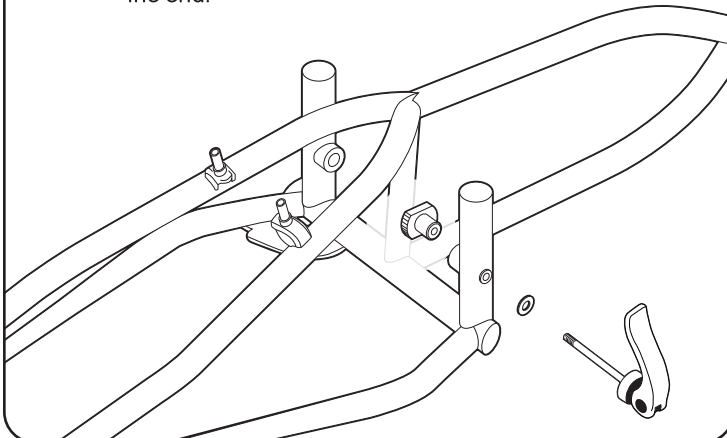

**STEP 3**

Insert the small quick release into the tongue as shown. Attach the special Tongue Nut to the end.

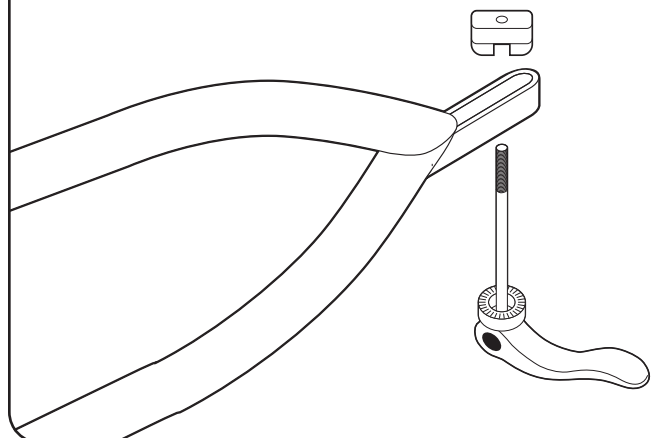

**STEP 4**

Insert the Free Radical frame into the bike frame from the rear.

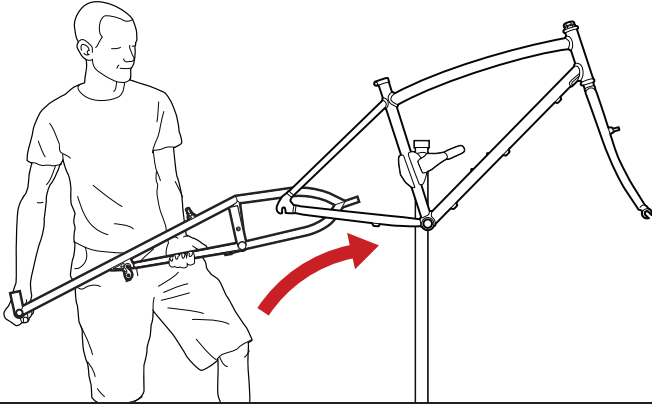

**STEP 5**

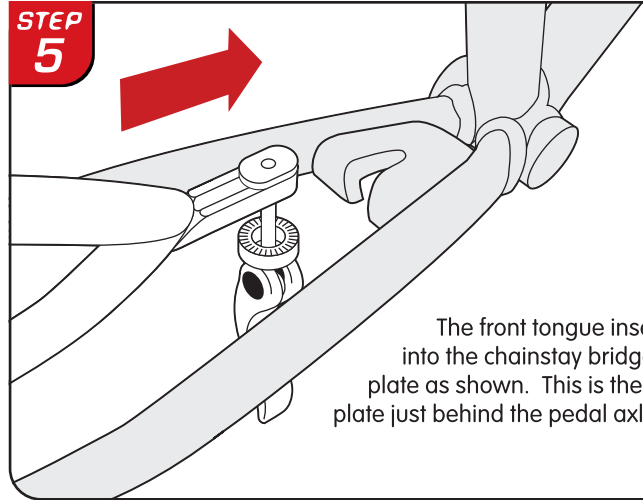

The front tongue inserts into the chainstay bridge plate as shown. This is the small plate just behind the pedal axle.

**STEP 6**

The French Nuts fit inside the bike's dropouts.

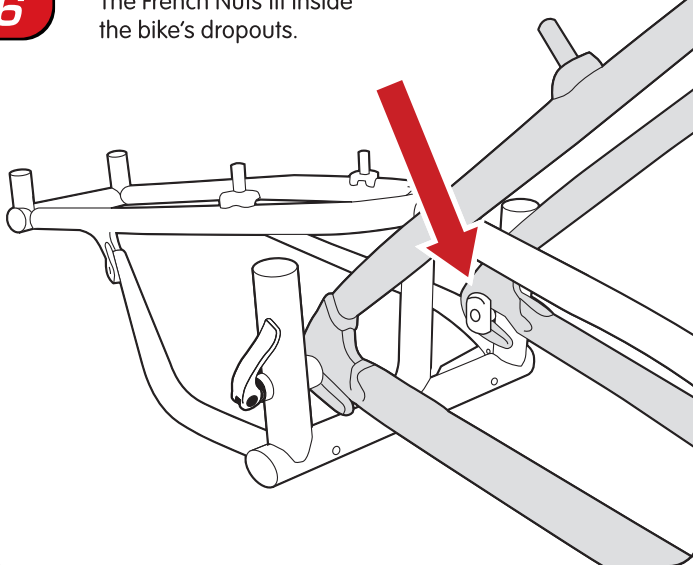

**STEP 7**

Have a friend or a large weather balloon hold up the back end of the Free Radical while you tighten down the three quick release bolts. It's usually easiest to tighten the rear two first, then tighten the tongue down.

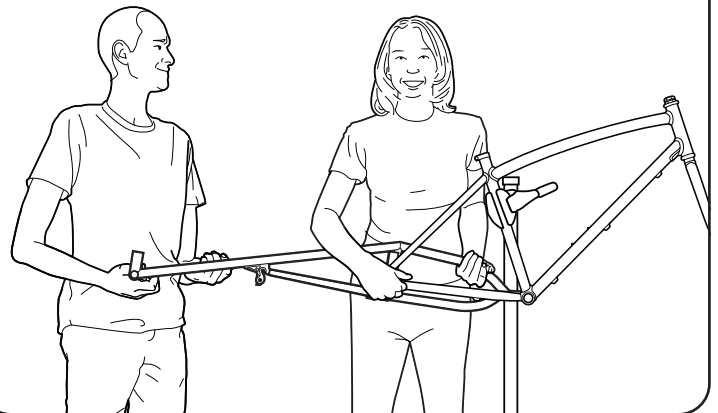

**STEP 8**

Using a 5mm allen wrench, install the brake caliper...

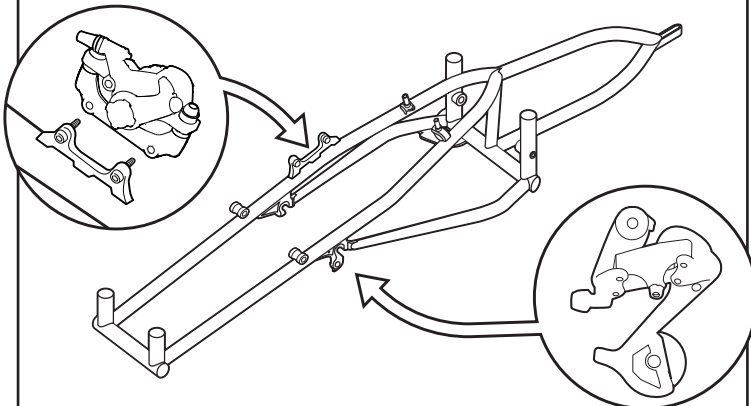

...and the rear derailleur. You will need to readjust these when the bike is fully assembled.

**STEP 9**

Install the remaining parts as you would on a normal bike. Note that you will need to install the rear fender before installing the rear wheel!

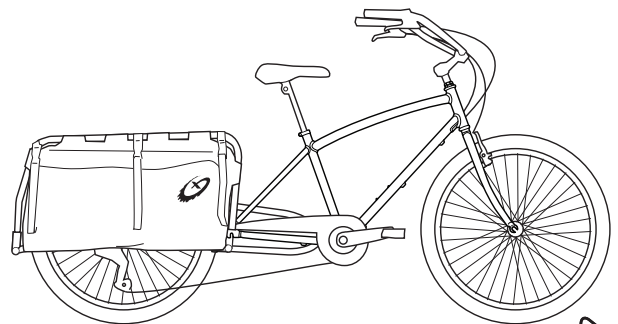

Continue with the Longtail Kit instructions to finish off the assembly!